

# **BSC-4000**

*Advanced Brush Technology  
Controller*

## Installation Instructions and User Manual

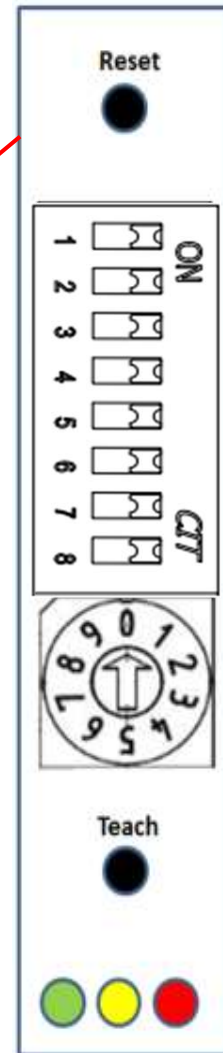
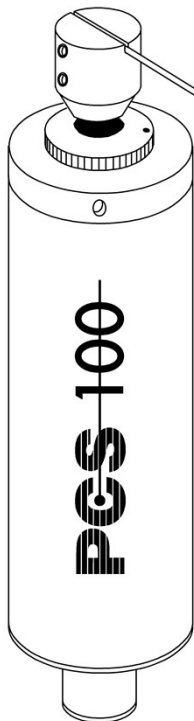

*Made in the  
USA*



# Table of Contents

<b>TOPIC</b>	<b>PAGE</b>
BSC-4000 System Specifications .....	1
General Use and Product Description .....	2
Determining Mounting Position .....	3
Mounting Bracket – Swing Arm Assembly – Swing Angle Setting .....	4
Proper Swing Arm Placement Relative to the Tool Tip .....	5
Front Panel Controls for the BSC-4000 .....	6
Gable Connection – Controller Installation – Home Position Option .....	7
Autorun (Demo Mode).....	8
Daisy-Chain Option .....	9 & 10
Basic Wiring Diagram and Layout .....	11
TB2 Terminal Block .....	12
TB3 Terminal Block .....	13
TB4 Terminal Block .....	14
Terminal Description – System Fault .....	15
Start Input, Reset & Reboot Functions – Input Signal Length .....	16
Contact Force (“CF”), and Cycle Time (“CT”) Setting .....	17
Default Switch Settings – ESD/EMF Protection – Check your Installation .....	18
PCS-100 System Troubleshooting Guide .....	19 & 20



# BSC-4000 Control Unit

## Specifications

### **BSC-4000:** Brushless Controller

**Power Input:** 24VDC, 2.0A

**Control Inputs:** NPN or PNP Type  
11mA each.

**Relay Contacts:** 5A @ 125VAC, general use  
5A @ 30VDC, resistive use  
"dry" contact type

**Operating Temp:** 0 - 55°C

**Mounting:** 35mm DIN Rail

**Wiring For Terminal Plugs:**

Wire size: Solid or Stranded, 16-28 AWG

Screw: M2

Torque: 3lb-in/0.2Nm.

**Materials:**

Enclosure: ABS, Polycarbonate

Terminal Plugs: Thermoplastic UL94 V-0

Clamp: Brass Ni Plated

Screw: Steel Zinc Plated, slot type

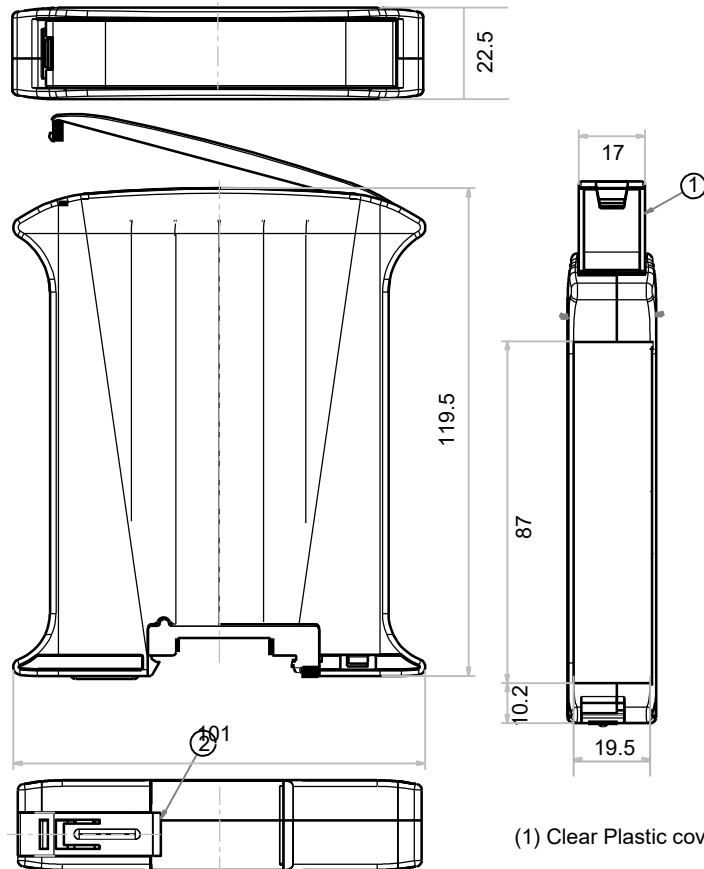

(1) Clear Plastic cover

(2) DIN Rail Clip

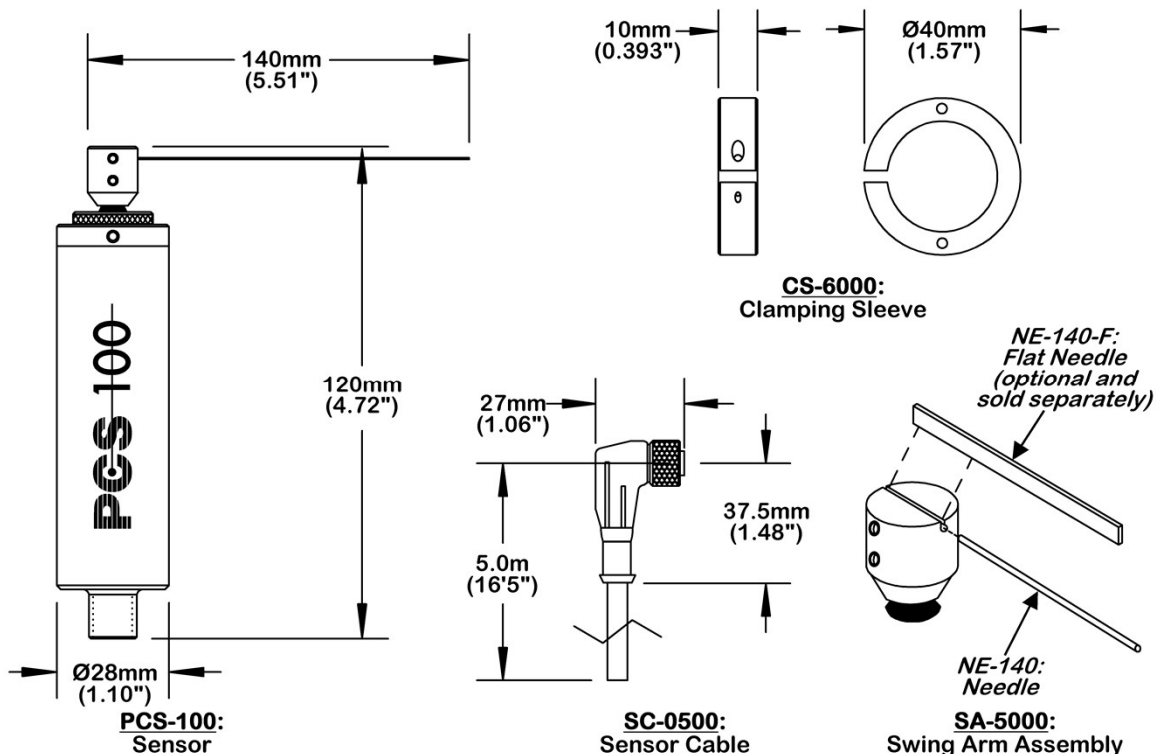

## 1. General use / description

The **BSC-4000** Control Unit has been developed to replace the Legacy unit known as the SCU-100.

Aside from an improved appearance as well as the updated componentry, the basic functionality of the system remains unaltered.

The **BSC-4000** Control Unit offers a simple interface between the sensor and the machine tool, eliminating the need for a specialized technician to perform the system integration.

The **BSC-4000** Control Unit, once properly connected to a PCS-100 Sensor would respond by turning the System LED Blue

As per its predecessors the System can be used to monitor “Part Presence” or “Free Space”. In a “Free Space” monitoring mode, hitting something during the test cycle will be indicated as a “Fault’

An example of this type of application is monitoring a bar cutoff, where a non properly cut bar would result in a “Fault”

## 2. Before you start

When a PCS-100 Sensor is connected to a properly wired and powered **BSC-4000** Control Unit, the sensor is immediately ready to operate. The initial Sensor rotation, whether it be Clockwise (CW) or counterclockwise (CCW) direction, is based on the chosen Dip Switch selection. The Swing Arm will swing against the Sensor Internal Stop (the “Home Position”), and it is now ready to operate in accordance with the parameters selected on the Control Unit for Cycle Time (the “CT”) and Contact Force (the “CF”).

To achieve and maintained proper operation it is critical the CW or CCW direction on the BSC-4000 is set in conjunction with the Adjusting Ring mechanical setting on the PCS-100 (see Page 4, section 6). Therefore, if the Sensor Swing Angle is set between 5° and 175° on CW, the Dip-Switch directional setting must be placed on CW and vice versa for the CCW direction

### *Please Note:*

The rotational direction, CW or CCW, is determined by the rotation of the swing arm when looking directly at the top of the sensor. Please see Page 3, Figure (2) for example of CW rotation.

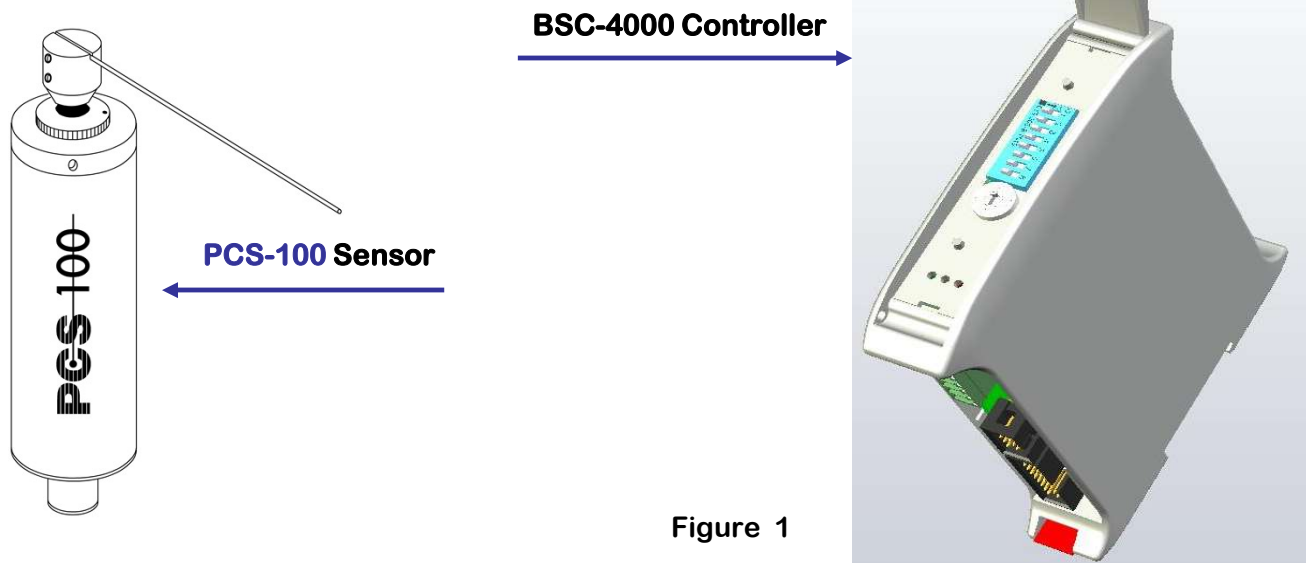

### 3. Determine the mounting position

There are several factors to consider when mounting the sensor. The space available in the tooling area will often dictate the mounting method and location. While **ALL** machine power is **OFF**, hold the sensor by hand sensor in the tooling area to determine the best placement. It is important to determine the desired Swing Arm Home Position and remember the sensor can swing in a CW or CCW direction.

Some of the variables affecting a decision of where to mount a sensor are listed below:

- a) **Rotational direction:** Clockwise (CW) or counter-clockwise (CCW) swing direction.
- b) **Swing angle:** Make sure the range of angular travel for the Swing Arm Assembly reaches the "Item". Typically, the sensor is placed with its Home Position relatively close to the "Item" being detected, to reduce to a minimum the detection cycle time.

For a PCS-100 Sensor, the most common swing angle selection is approx. a 90°, Figure 2. The max. swing angle is approx. 175°.

This applies to either CW or CCW swing direction.

- c) **Mounting Bracket:** A special mounting bracket may need to be fabricated to hold the Sensor in place. A CS-6000 Clamping Sleeve is typically provided with each PCS-100 System. If a special bracket is required, please refer to the machining specs shown in Figure 3.

- d) **Needles and Flat Wands:** The standard Needle length (as shown in Figure 4), may be used. A shortened Needle may also be used, or a longer Needle (up to 8"), may be purchased separately.

Flat Wands are ONLY available in a length of 155 mm.

If a straight Needle or Wand does not suit individual needs, the Needle may be bent into any desired configuration (*i.e. to swing past an obstruction*).

Two examples are shown in Figure 5.

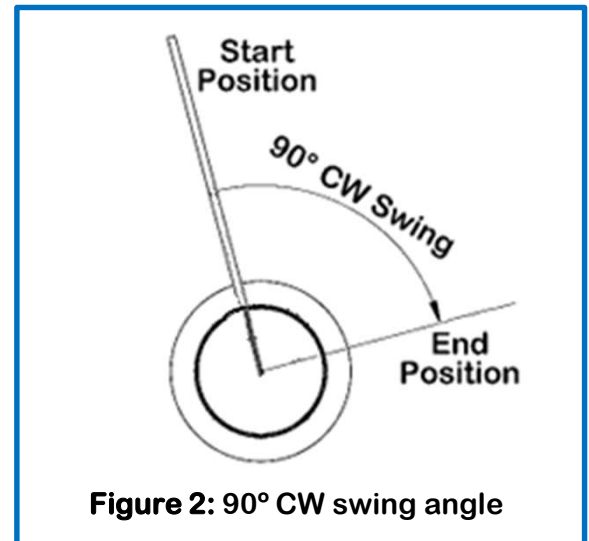

Figure 2: 90° CW swing angle

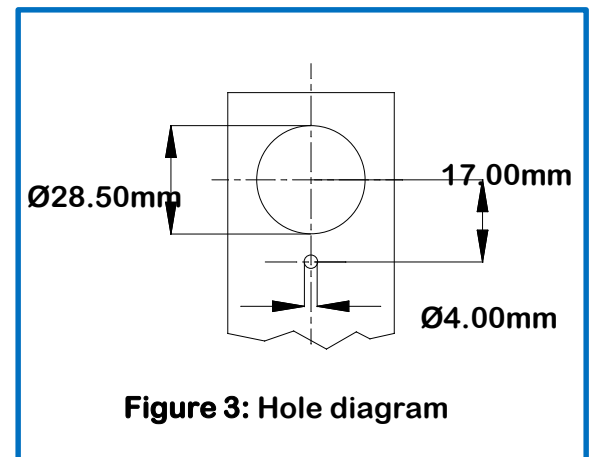

Figure 3: Hole diagram

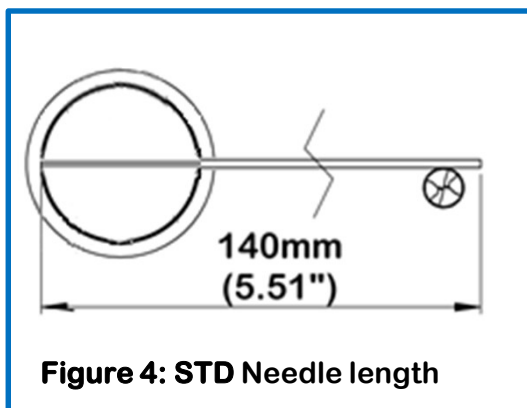

Figure 4: STD Needle length

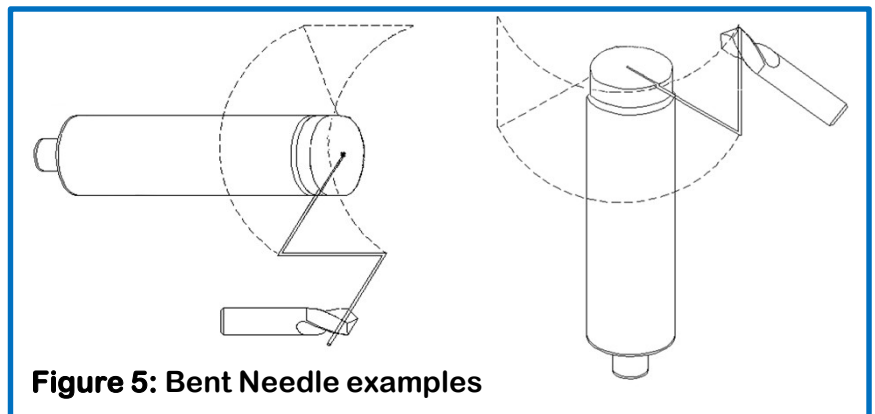

Figure 5: Bent Needle examples

#### 4. Install the mounting bracket and mount the Clamping Sleeve

The Clamping Sleeve is used to hold the Sensor and allows for attachment to the mounting bracket fabricated by the customer. Each Clamping Sleeve is packaged with a screw and nut which can be used to mount the Clamping Sleeve to the mounting bracket. Figure 5 illustrates a typical mounting example.

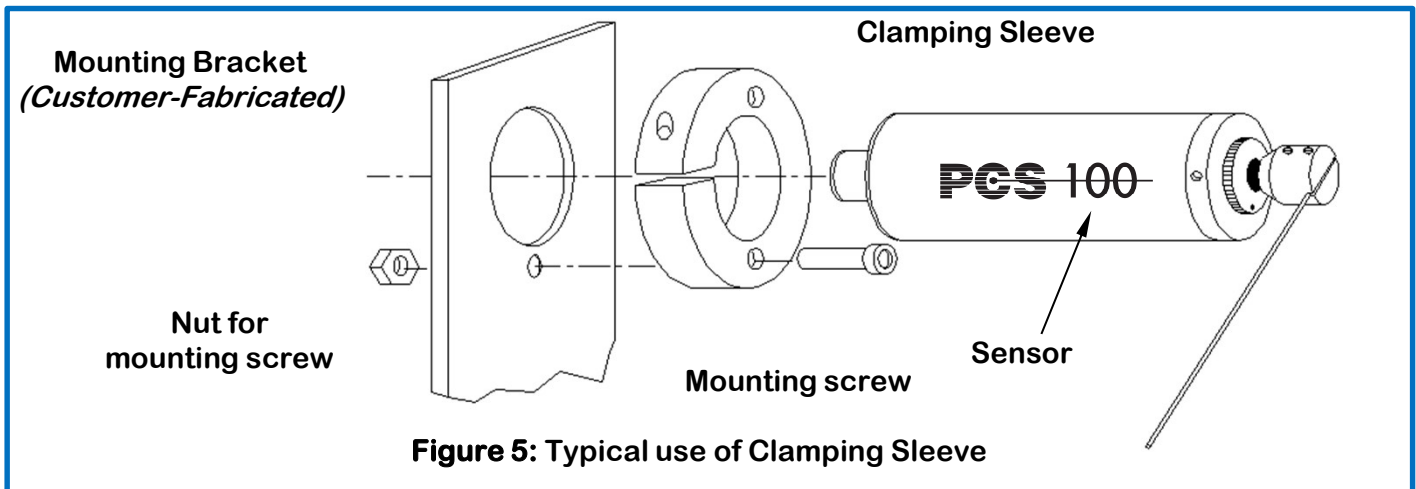

Figure 5: Typical use of Clamping Sleeve

#### 5. Loosen and remove the Swing Arm Assembly

If you have already mounted the Swing Arm Assembly, we recommend removing it at this point. Use a 1.5mm hex key to loosen the two opposing set screws on the Swing Arm Assembly (indicated "A" in Figure 6) and slide the Swing Arm Assembly off the Sensor.

#### 6. Set swing direction and swing angle

The PCS-100 Sensor features an adjustable swing angle which can be set between 5° and 175° in either a CW or CCW direction. The Sensor can be preset at the factory to your specifications. If you did not specify a swing direction and swing angle in your order, the Sensor is set to 90° CW (as shown in Figure 7). Swing direction and swing angle are established by referencing the red mark on the knurled adjusting ring while looking at the shaft of the Sensor straight on. There are lines indicating each 45° increment as illustrated in Figure 7.

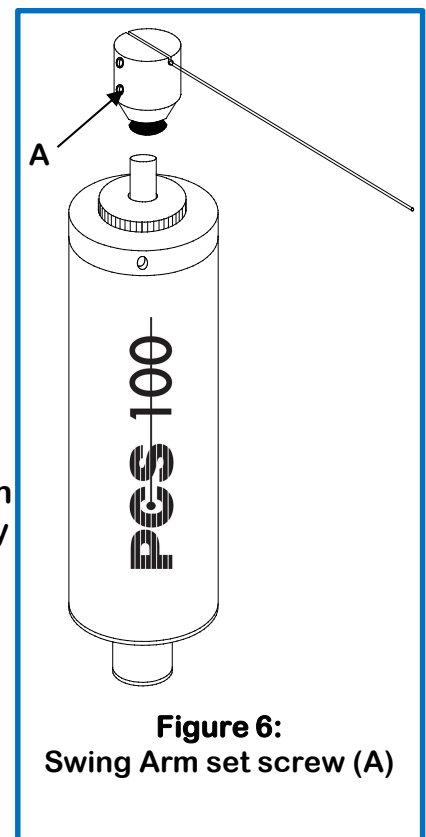

Figure 6:  
Swing Arm set screw (A)

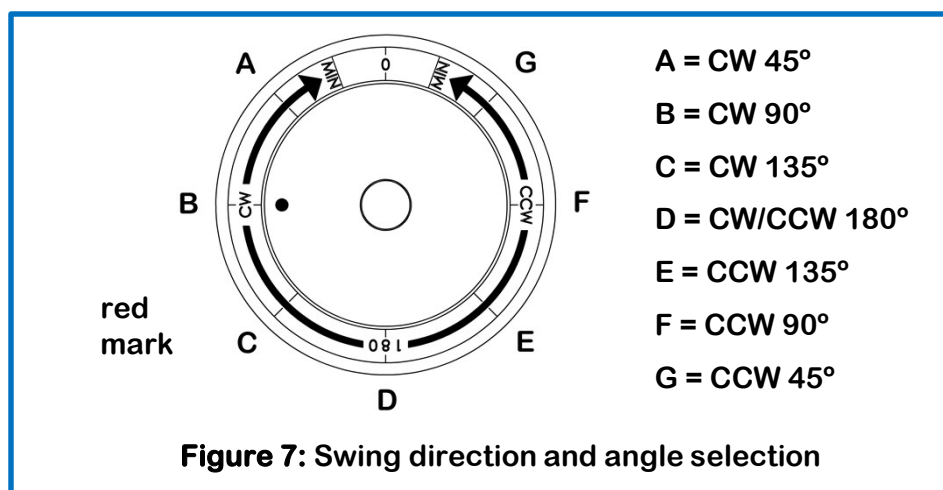

Figure 7: Swing direction and angle selection

To change the swing direction or swing angle, loosen the set screw (indicated “A” in Figure 8) until the knurled adjusting ring (indicated “B” in Figure 8) can be manually rotated.

Turn the adjusting ring to the desired swing angle in either the CW or CCW field. If you are changing swing direction (CW/CCW) always move away from the “Zero Zone” indicated in Figure 9, and **PAST** the 180° mark (by at least 5°). Once you have passed the 180° mark, the Sensor will operate in the CW or CCW field it is in. **The adjusting ring will not move through the “zero zone”**. Once the desired swing direction and swing angle are set, tighten set screw (A).

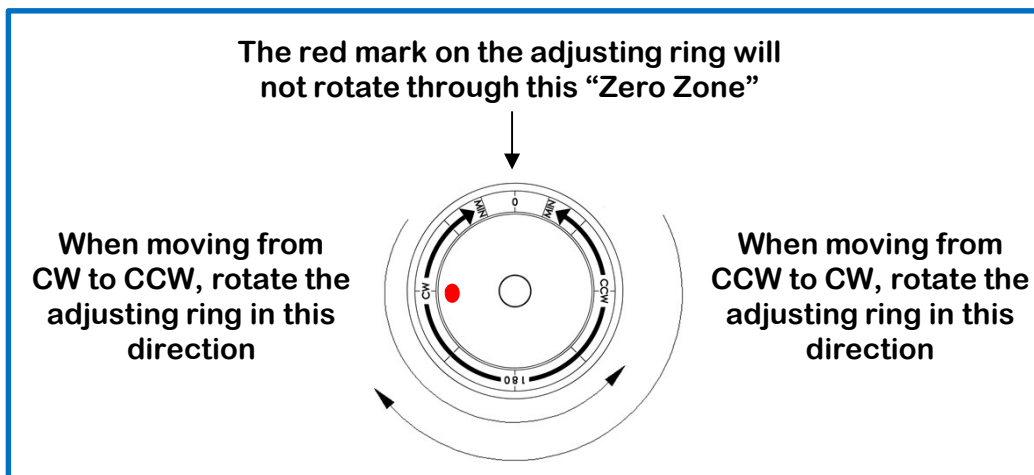

Figure 9: Adjusting ring movement

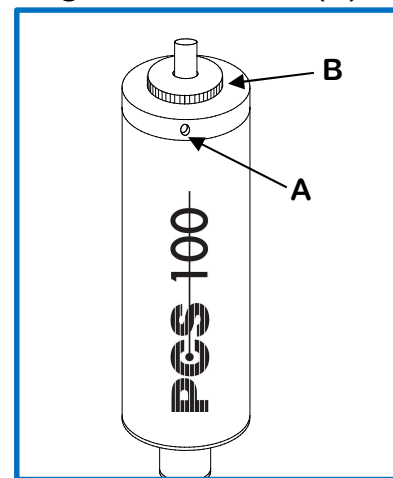

Figure 8: Swing angle adjustment

## 7. Proper Swing Arm Placement relative to a Tool Tip and Monitoring Zone

- With the Swing Arm Assembly already mounted on the Sensor, and the Clamping Collar slightly loose, slide the Sensor forward or backward to position the Needle so that it will contact the tool/object, and at the same time verify that the Needle extends past the centerline of the tool/object as shown in Figure 10.
- In the event the needle or flat wand doesn't reach or doesn't go past the centerline of the tool, reposition the needle or flat wand in the swing arm assembly, choose a different location for the Sensor, or purchase a longer needle.
- For proper monitoring, the swing arm should be allowed to travel freely by approx. 10° before coming in contact with the tool/object being monitored, see Figure 11. With a broken tool or a missing object, the swing arm will travel to the end of the swing angle
- The swing arm will then return Home and wait for a new command, Reset or Start.

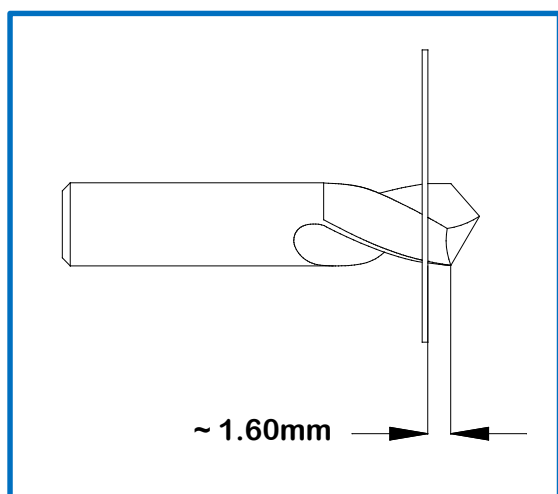

Figure 10: Needle alignment

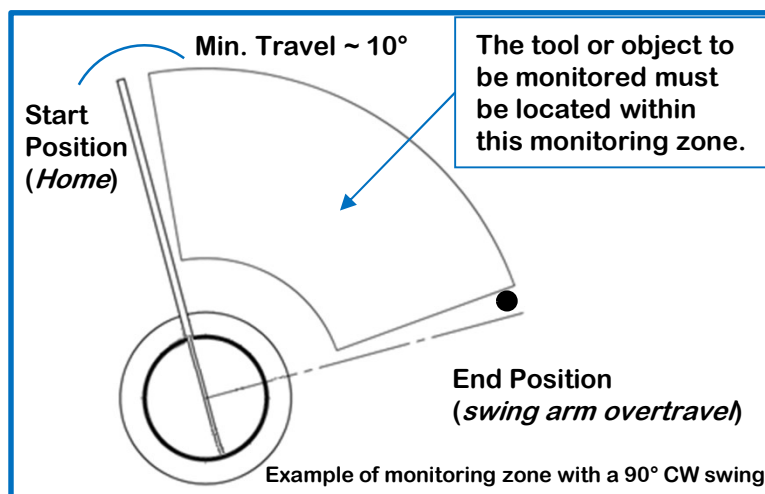

Figure 11: Needle Detection Range

# Front Panel Controls for the BSC-4000

### Reset Button:

- Clears fault relay, if active.
- Clears System Fault, if active
- Two presses within 1sec will cause a sweep
  - (Replicating the Start 1 Signal function)
- Three presses within 1 sec will cause a sweep
  - (Replicating the Start 2 Signal function)

*This is a redundant start for the PCS-100*

### Please Note:

Teach\* and Reset buttons, on this panel, function identically and in parallel with their respective external control inputs.

However, external resets, will not initiate a sweep

### Please Note:

Normal Tolerance "NT" & Extended Tolerance "ET", **ONLY** Applies to PCS-250 Sensors.

Refer to specific PCS-250 Instructions for details regarding this feature

Controller Dip-Switches default settings is **ON**

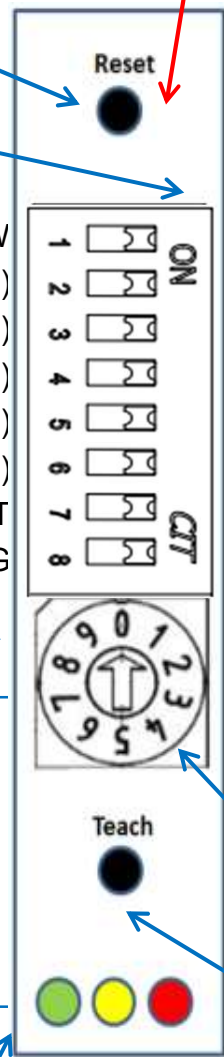

DIRECTION CCW  
 NORMAL LOGIC (NL/**ET**)  
 OK RELAY LATCHED (LAT)  
 OK RELAY NORMALLY CLOSED (NC)  
 FAULT RELAY LATCHED (LAT)  
 FAULT RELAY NORMALLY CLOSED (NC)  
 NO COMMON START  
 CYCLE TIME SETTING

DIRECTION CW  
 (RL/**NT**) REVERSE LOGIC  
 OK RELAY MOMENTARY (MOM)  
 OK RELAY NORMALLY OPEN (NO)  
 FAULT RELAY MOMENTARY (MOM)  
 FAULT RELAY NORMALLY OPEN (NO)  
 COMMON START  
 NORMAL POSITION AFTER CYCLE TIME IS SET

**Please Note:** The Force settings 0, 1, & 2, are recommended to accommodate monitoring fragile targets.

The cycle time should also be set proportionally, to assure the wand reaches the object, yet it doesn't sit on it for too long possibly damaging the fragile target.

Rotary switch also sets Cycle Time when the switch is moved to the Off position and back On.

'0' is the least aggressive setting for Contact Force & the shortest Cycle Time

Default settings is 4 for both

### LED Behavior:

- LED GREEN – Sweep result OK
- LED RED SOLID – Sweep FAULT
- LED RED BLINK – System FAULT
- LED YELLOW SOLID – Teach mode \*

### Teach Button

- This button is only utilized for Special Function.
  - See Page 12 for Functions details
- \* Actual Teach Functions Available for PCS-250 ONLY**
- This also applies to the external 'Teach' input***

## 8. Cable Connection to the Sensor

Once a Sensor is properly secured, connect the Sensor Cable to the Sensor making sure the Cable Nut is suitably tightened. This step is critical to assure the connector internal O-ring is properly compressed, thus ensuring proper shielding of the connector pins from external contaminants.

***Please Note:*** If the Sensor Cable needs to be re-positioned while attached to the Sensor, loosen the Clamping Collar, and rotate the entire Sensor; this is to avoid damage to the sensor connector and/ or the cable.

## 9. Controller Installation and placement

Mount the BSC-4000 Controller in the electrical cabinet using the 35mm DIN Rail mount. Make the appropriate electrical connections to the 24VDC power supply and plug the respective Input and output Terminal Block Plugs. Please reference pages 11 through 16 for Terminal Descriptions and detailed wiring instructions.

Make sure the Sensor cable is properly routed from the sensing area to the Controller and avoid wrapping the cable around moving parts or sharp objects that could otherwise damage the cable and the integrity of the installation.

Once Power is supplied to the Controller, the Controller and the Sensor (if connected) will turn on and the Sensor Swing Arm will immediately rotate based on the directions established by the Dip-Switch setting.

***Please refer to Pages 7 through 19 herein, for all other details relating to Installation, Wiring and operation of the BSC-4000***

## 8. Home Position on a PCS-100

On the **PCS-100** Sensors the “Home Position” is mechanically set, internally to the Sensor.

Following the initial boot-up process, the Swing Arm Assembly rotates against the Sensor Internal stop “Fixed Stop”, in the CW or CCW direction, based on the Controller Dip Switch setting. This Specifies, the Sensor’s “Home Position”.

To achieve and maintained proper operation it is critical the CW or CCW direction is set in conjunction with the Adjusting Ring mechanical setting. (see Page 4 point (6.)). Therefore, if the Sensor Swing Angle is set between 5° and 175° on CW, the Dip-Switch directional setting must be placed on CW and vice versa for the CCW direction

***Please Note:*** Incorrect setting will result in a System malfunction and the inability of the sensor to properly perform the detection function.

Every time the system is powered down and back up, the Green, Yellow, and Red LED will light for approximately 5 seconds, and go off at the completion of the boot process.

The Swing Arm will once again rotate in the preselected direction and stop against the internal “Fixed stop” at its “Home” position.

***Please Note:*** The “Home Position” or “Fixed Stop” it is not changeable .

## 10. Autorun (Demo Mode)

- ❖ The Controller is equipped with an Auto-cycle – (“Demo Mode”) feature, a useful option to test the swing cycle and wand position during set up, without needing to send an external or a PLC input each to prompt the sensor to sweep.
- ❖ To activate this cycle, while pressing and holding the “Reset” button on the Controller front panel, press the “Teach” button for approximately 1 sec., release the “Teach” button and then the “Reset” button.
- ❖ Autorun is now active. The swing arm start monitoring in the direction it was taught. If only one position was taught, the wand will only swing in one direction, if two positions were taught, the wand will swing in both directions alternating between CW and CCW, regardless of the Dip-Switch rotational settings.
- ❖ To exit Autorun, momentarily press the “Reset” button or toggle power on the Controller.

**Please Note:** A press and hold of the “Reset” button for 5 sec. will also stop Autorun and will reset all learned parameters except the “Home” position that it is permanently retained until manually reprogrammed.

## Daisy-Chain Ribbons

### Optional

A group of Controllers can be daisy-chained together to reduce wiring.

- ❖ Two ribbon connection locations are provided, one 6 pin and one 16 pin.
- ❖ The connections may be used independently
- ❖ The larger 16 pin ribbon, distributes 24V, 0V, Earth and CAN-bus.
- ❖ The smaller 6 pin ribbon, distributes both Start Signals, Reset, and Teach.
- ❖ Teach and Reset signals are always distributed across the ribbon.
- ❖ The Start signal distribution is controlled by the front panel Dip-Switch setting of each individual Controller (The default setting is ON)

### Please Note:

- ❖ Relay signaling Outputs are not included in the ribbon, and act independently on all Controllers
- ❖ Each Controller operates its own sensor based on the individual Controller Settings.
- ❖ No more than four (4) Controllers can be Daisy-Chained together; however, multiple sets of Daisy-Chained Controllers may be connected together, via the bus connection TB5 (see details explained under TB5 description)
- ❖ Even with connected ribbon(s), individual Controllers can be excluded from the Daisy-Chain operation by switching the appropriate Dip-Switch of that Controller to the Off position.

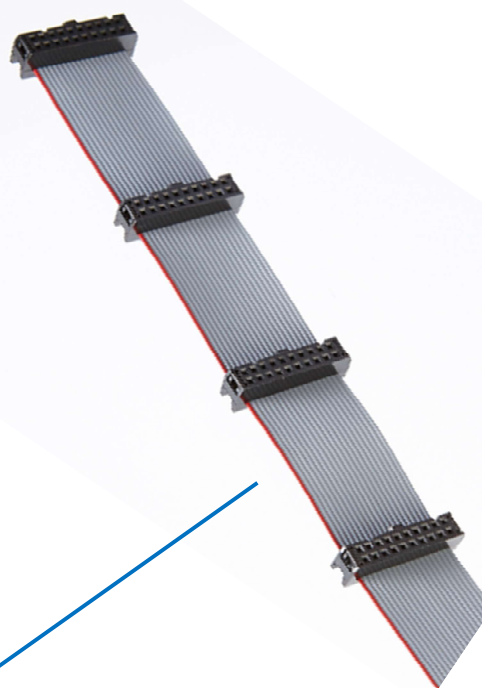
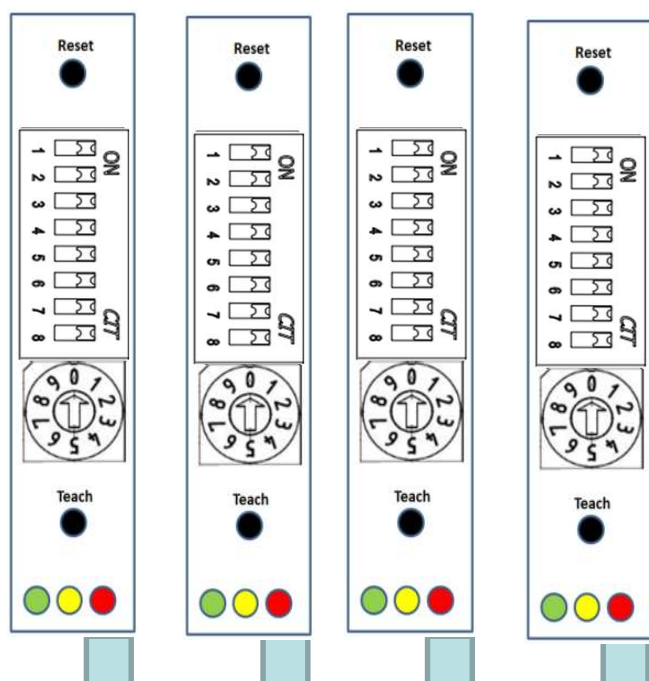

## Daisy-Chain Ribbons (Continued)

- ❖ J4 and J5 terminals, are IDC for ribbons dedicated to Daisy-Chaining Controllers.
- ❖ Each ribbon may be used independently.
- ❖ The unused Daisy-Chain ribbon cables may be cut with sharp scissors or razor blade to remove unwanted/extra connections or simply left floating.
- ❖ J5 allows TB3 Power and TB5 OEM Bus to be connected at one Controller, then distributed to the other Controllers.
- ❖ J4 distributes Starts, Teach, and Reset controls, to the additional Controllers.
- ❖ When a Daisy-Chain ribbon is in place, Teach and Reset circuits are always distributed across the Controllers.
- ❖ One wired Controller will control the others. This reduces system wiring complexity.
- ❖ The Start circuit distribution is controlled from a front-panel Dip-Switch setting. This allows for units to be simultaneously or independently started.
- ❖ If simultaneous starts are desired, one unit can be wired with the start signal; the others will be started through the Daisy-Chain connection. Otherwise, each unit would require its own start signal
- ❖ To isolate a single Controller from the Daisy-Chain operation set the Dip-Switch to the off position

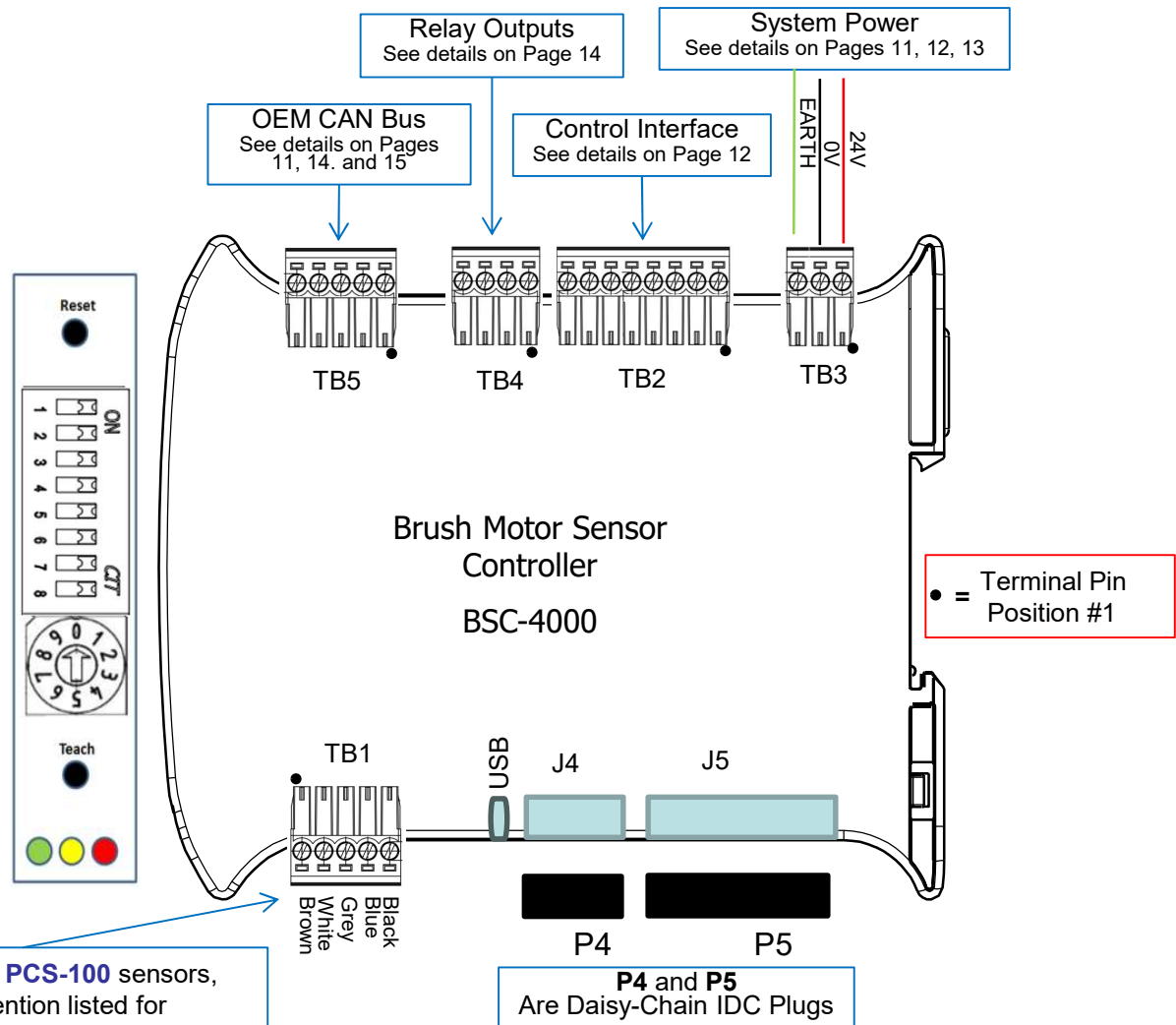

# Basic Wiring Diagram and Layout

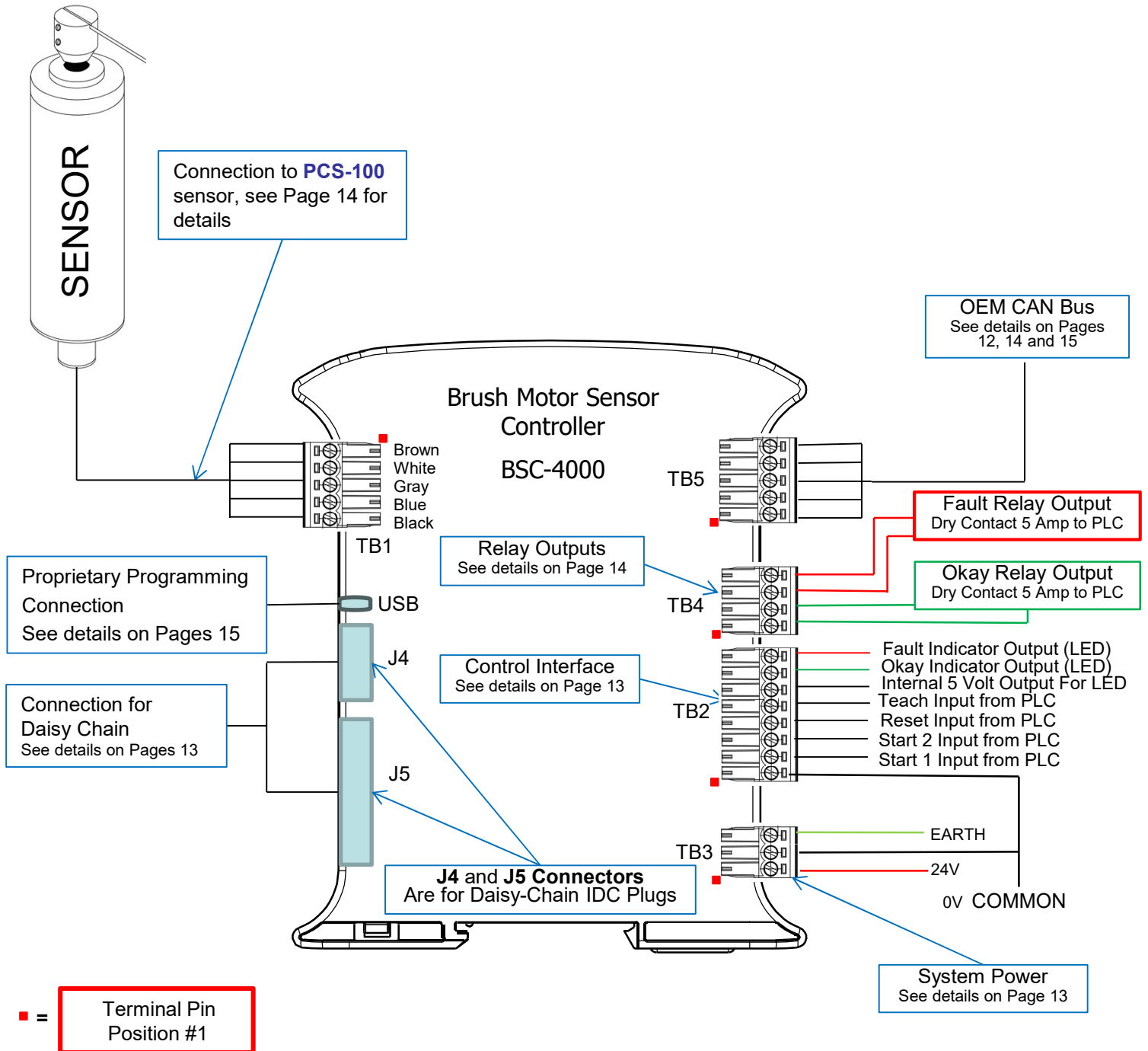

## TB2 Control Interface Details

This interface provides four 24VDC control inputs, and a power-limited 5VDC source, and two open-collector type outputs for status indication.

**Please Note:** The “Common” for the inputs, is provided at (Pin 1), and not connected internally.

This may be connected to 24V for NPN, or to 0V for PNP type per the signal of PLC output.

### The 4 Control Inputs (For the 8 Pin Terminal Block):

- Pin. 2 *Start\_1* Initiates a sweep cycle. Also used to learn a position if “Teach”\* is activated
- Pin. 3 *Start\_2* Initiates a sweep cycle. Also used to learn a position if “Teach”\* is activated
- Pin. 4 *Reset* Clears a Fault condition when activated. Also used to exit a “Teach” function
- Pin. 5 *Teach* First activation places the unit into “Teach” Mode.  
A second activation will initiate the sweep to learn the First Position  
A third activation will initiate the sweep to learn the Second Position

### Please Note:

- The sweep direction (CW or CCW), is based off the Dip-Switch setting.
- If two positions are being monitored and Start\_1 was used to learn location 1, this Start must be used to monitor location 1. The same applies to Start\_2.  
Likewise, if Start\_1 was used to learn location 2, this Start must be used to monitor location 2.

## \*Actual Teach Functions are Available for PCS-250 ONLY

The 5VDC source and 2 open collectors provide a mechanism for remote status indication.

These can drive LEDs to indicate ‘Teach Mode’\* and ‘Fault’ conditions.

These signals follow the front panel indication.

\*\* DO NOT CONNECT TB2-7 OR TB2-8 to 24V.  
Q3 OR Q4 WILL BE DAMAGED

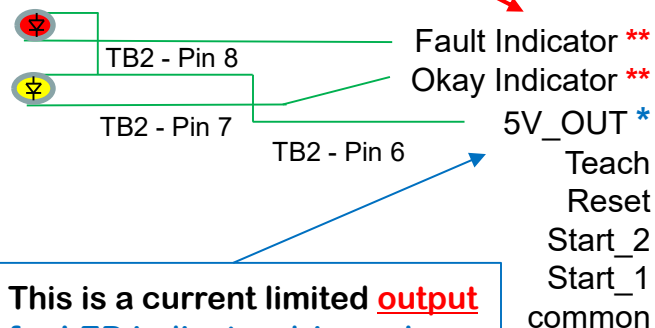

\* This is a current limited **output** for LED indicator drive only.

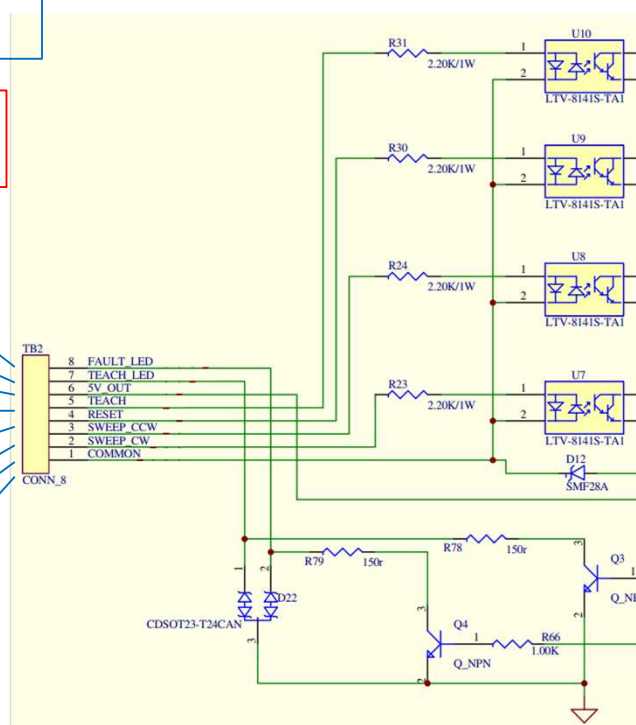

# TB3 System Power and Power Distribution

**Input power:** 24VDC ± 10%

**Current consumption:** 2A max

- ❖ The controller is protected internally by self-resetting PTC overcurrent devices.
- ❖ Under idle conditions the Controller draws less than 100mA current. Very brief current spikes are produced during swing arm acceleration/deceleration.
- ❖ **No more than 4 units are to be connected via ribbon (Daisy-Chained)**

## Power distribution for daisy-chain connected units:

**Please Note:** DUE TO CURRENT CARRYING RESTRICTION AND COMMUNICATIONS CONVENTION, ONLY ALLORA PROVIDED DEVICES MAY BE ATTACHED TO TB5

**\* Please Note:** Fuse size to be properly selected based on the number of units on the bus. A 1A slow blow fuse is advised for up to 4 Controllers in a Daisy-Chain

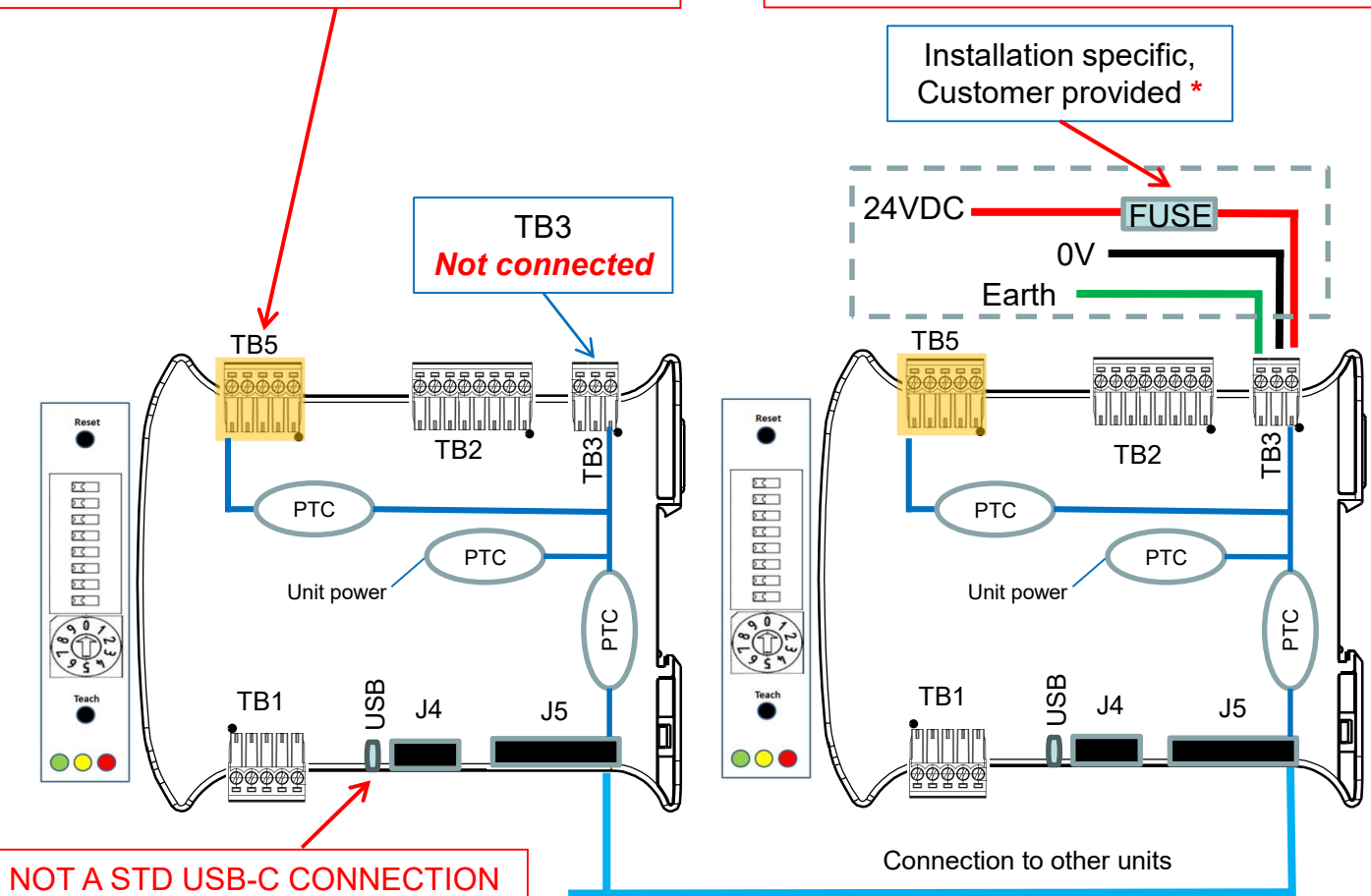

**NOT A STD USB-C CONNECTION ONLY ALLORA'S PROPRIETARY DEVICES MAY BE CONNECTED TO THIS TERMINAL (see page 15)**

**ONLY ALLORA PROVIDED DEVICES MAY BE ATTACHED TO THE RIBBON**

**Please Note:** Ribbon cable illustrated above, only shows the 24V connection; 0V, Earth, and CAN Bus signals are also shared via the ribbon but not shown.

## TB4 Output Signal Relays Connection

Relay Contacts rated at:

5A @ 125VAC, general use

5A @ 30VDC, resistive use

Relays are 'dry' contact types (no voltage is present)

Two relays are provided to signal for OK and/or FAULT responses to a "Teach"\* and Detect Sweeps

Relay operation is unaffected by Daisy-Chain ribbon connections.

They operate independently of each other on each Controller.

When operating in the non-latching mode, toggle time is approx. 100ms

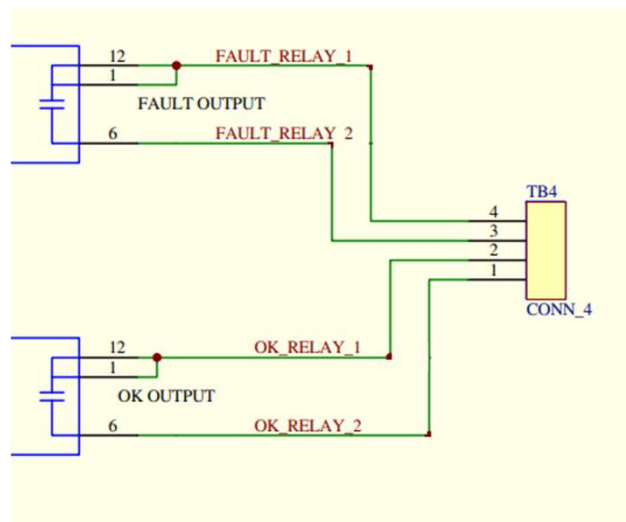

**Please Note:** Certain solid-state devices may output a small amount of current in their off (low) state. Depending on the operating characteristics of these devices, the Controller may not recognize a change of state. If this condition occurs in your application, you may need to incorporate an external relay to activate the Start/Reset Inputs.

### EXCLUSIVE WIRING FOR PCS-100 AND PCS-250 ONLY

### TB1 and TB5 wiring details

#### TB1

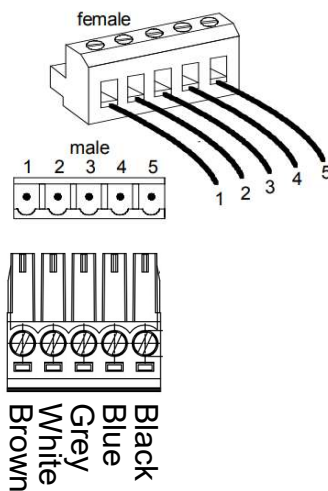

#### 7.3 Open style connector

#### TB5

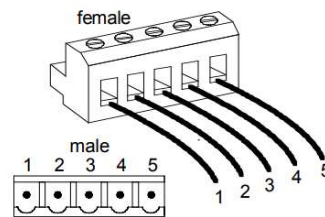

If Open Style Connectors are used the following pinning is recommended:

Pin	Signal	Description
1	CAN_GND	Ground / 0 V / V-
2	CAN_L	CAN_L bus line (dominant low)
3	(CAN_SHLD)	Optional CAN Shield
4	CAN_H	CAN_H bus line (dominant high)
5	(CAN_V+)	Optional CAN external positive supply (dedicated for supply of transceiver and opto-couplers, if galvanic isolation of the bus node applies)



## BSC-4000 Controller

- Terminal Descriptions Summary
- General Notes and Comments

- TB1** A (5) position Connector/Plug, used to plug the Sensor to the Controller via a properly sized shielded cable, (See Page 14).
- TB2** An (8) position Connector/Plug, used to wire a control interface, (See Pages 10, 11, 12).
- TB3** A (3) position Connector/Plug, used to wire a 24VDC power supply, (See Pages 10, 11, 13).
- TB4** A (4) position Connector/Plug, used to wire the relays outputs, (See Pages 10, 11, 14).
- TB5** A (5) position Connector/Plug, for Allora's select devices, (See Pages 10, 11, 12, 14, 15).
- USB** Proprietary USB Type C connection for factory use ONLY. \* (See Pages 11, 13)

**\* Please note: This is NOT A STANDARD USB. Do not connect to a standard USB cable or device, as severe damage may be caused to the controller thus voiding its warranty.**

- ❖ All Plugs should be wired in advance of being connected to the Controller, and all wires should be properly secured by each screw of the respective plug, and properly torqued (**See Page 2**).
- ❖ For terminal TB1, Sensor Cable Plug connection, the colors indicated correspond to wire colors of Sensor Cables. The preferred method is for the Sensor Cable to be uninterrupted, therefore, a single cable from the Sensor to the Controller should be employed. If the Sensor and Control need to be connected via external junction box, avoid wiring near electromagnetic or high current devices.

### **SEE ATTACHED NOTES:**

**THE SENSOR CABLE BRAIDED SHIELD SHOULD BE CONNECTED TO THE MACHINE FRAME/EARTH!**

#### **❖ SYSTEM FAULT:**

- A System Fault condition (*shown by a blinking Red LED*), is typically due to hardware failure:
  - The controller is unable to communicate with the sensor:
    - The cable is not properly connected to the Sensor
    - The cable is not properly connected to the Controller
    - The cable is damaged
  - An internal failure to the controller is detected
  - An internal failure to the sensor is detected
- After correcting the condition causing the fault, the recovery procedure is to press either the front panel "Reset" button or activate the External Reset signal.
  - The controller will cycle power to the sensor, self-reset, and command the sensor to its home position. The green OK LED will activate on success.
  - If unobstructed, the swing arm will return normally to its home position.
  - The system is now ready to resume normal operation.



## **BSC-4000 Controller**

- Terminal Descriptions Summary
- General Notes and Comments

*Continued*

### ❖ **START, RESET BUTTON FUNCTIONS and CONTROLLER REBOOT:**

#### ***Please Note:***

**Under normal operation, the Start Input can also be used to Reset a Sweep Fault, (*i.e., a fault caused by a broken tool*); a Start Input will NOT clear a System Fault condition.**

- Applying a Start Input will cause the Sensor to initiate the sweep in the CW or CCW direction, based on the Dip-Switch setting, if the condition which caused the fault has changed, and the sensor makes a clear sweep, an Okay result (*green LED will light*) will appear,
- Each Start input acts independently from one another.
- An actual System Fault from a mechanical malfunction of the System will require a “Reset” signal to re-establish normal operation (see System Fault details on Page 15).
- To Reboot the Controller, either power down and back up the Controller, or press and hold the Reset button for ~5 seconds, when the Yellow LED blinks, release the Reset button. The Controller will now reboot, and the Swing Arm will return to its Home position (*for more information on Home Position, see Page 7*).

***Please Note:*** If rebooting the Controller by holding down the “Reset” button for 5 seconds, all previously set parameters are also reset, therefore, the CT setting are set to the default setting of four (4). The fixed “Home Position” is not affected by the reset

- Additional functions and detail of the Reset Button:
  - A single momentary press on the Reset button will clear a Fault Condition
  - When a Controller is operating in Autorun, (*see Autorun on Page 8*), a single momentary press on the Reset button will clear this function/mode.
  - Two (2) presses of the “Reset” button within one (1) second, equals a Start 1 Input signal; the Swing Arm will initiate the sweep CW or CCW based on the Dip-Switch setting
  - Three (3) presses of the “Reset” button within one (1) equals a Start 2 Input signal; the Swing Arm will initiate the sweep CW or CCW based on the Dip-Switch setting
  - Pressing and holding the Reset button for ~ 5”, will restart the Controller. This operation will also reset the sensor and erase the manually set CT value.

### ❖ **INPUT SIGNAL LENGTH**

All Input signal length, Starts, and Reset, should be for a minimum of 100ms.

***Please Note:*** Certain solid-state devices may output a small amount of current in their off (low) state. Depending on the operating characteristics of these devices, the Controller may not recognize a change of state. If this condition occurs in your application, you may need to incorporate an external relay to activate the Start/Reset Inputs.

## Dip-Switch SETTINGS: Contact Force (“CF”), and Cycle Time (“CT”)

### ❖ Dip-Switch Settings

- The default switch settings, of all 8 Dip-Switches is **On** (*Right, see Page 6*).

#### CF Settings

- The default “CF” setting is 4, (*see Page 6*)
- These default settings are appropriate for basic operations. Should your installation require deviation from the default settings, please refer to Page 6 and below for detail description of the functionality of the individual Dip-Switches and Rotatory Switch settings..
- An approximate value of each of the rotary setting, is indicated on the chart below:
  - Settings 0 – 2 are specifically tuned for Micro Tools
  - Settings 3 – 4 are tuned for the typical application (**4 is the default setting**)
  - Settings 5 – 7 are tuned for applications requiring higher torque (*erased, greater swing angle*)
  - Settings 8 – 9 is for extreme situations (*i.e. sticky coolant, longer needles, “up-hill” swing, etc.*)

**Please Note:** When selecting setting 3 – 9, it is best practice to choose at least one higher setting than the minimum required to produce a Fault condition (Tool Removed). This provides a cushion to accommodate for minor changes in machine environment while monitoring.

### ❖ CT Settings

- The default CT settings is 4.
- To establish the desired CT setting rotate the Rotary Switch knob to the number corresponding to the desired value (refer to “CYCLE TIME SETTING” on Page 6) and cycle the Dip-Switch No. 8 to Off and back On.
  - When back in the On position, the Rotary Switch will once again control the CF.

**Users should take the necessary steps to confirm the desired CF is reestablished.**

- Zero (0) is the shortest CT setting (Approx. 50ms) and nine (9) is the longest (Approx. 1,000ms) Each setting from 0 thru 5 increases the CT by approximately 50ms. Between settings 5 and 6 is a difference of 100ms, whereas the cycle time increases by approximately 200ms for each setting from 6 thru 9.

**Please Note:** If System Reset is performed, by pressing and holding the Reset button for 5 seconds, the customized CT setting is erased, and the default setting is reestablished.

## ❖ DEFAULT SWITCH SETTINGS:

- The default switch settings, of all 8 Dip-Switches is On (*Right, see Page 6*).
- The default Rotary Switch setting is 4, (*see Page 6*).
- These default settings are appropriate for the vast majority of installations. Should your installation require deviation from the default settings, please refer to Page 6 and below for detail description of the functionality of the individual Dip-Switches and Rotatory Switch.
- An approximate value of each of the rotary setting, is indicated on the chart below:
  - Settings 0 – 2 are specifically tuned for Micro Tools
  - Settings 3 – 4 are tuned for the typical application (*4 is the default setting*)
  - Settings 5 – 7 are tuned for applications requiring higher torque (*i.e. greater swing angle*)
  - Settings 8 – 9 is for extreme situations (*i.e. sticky coolant, longer needles, “up-hill” swing, etc.*)

When selecting setting 3 – 9, it is best practice to choose at least one higher setting than the min. required to produce a Fault condition (*Tool Removed*). This provides a cushion to accommodate minor changes in machine environment.

## ❖ ESD/EMF PROTECTION:

- ***Please Note:*** Various length shielded The BSC-4000 Controller is a microprocessor-based device equipped with overcurrent protection as well as additional electronic noise filtering devices, however, it is strongly recommended, when mounting the Controller in an electrical cabinet, to avoid placing the Controller near sources which might produce strong ESD (*Electrostatic Discharge*) or EMF (*Electromagnetic Frequencies*), such as large motor starters or high current devices.  
ESD/EMF may interfere with the proper operation of the Controller.
- The Sensor Cable supplied with the PCS Sensor System is fully shielded. The preferred installation method is to connect the wires of the Sensor Cable to the Connector Plug first, then plug the Connector Plug to the Controller (Connector TB1). If the installation requires connecting the Sensor to the Controller via a junction box/terminal-strip, avoid placing the joined connection near ESD/EMF sources.

**Sensor Cables are available upon request.**

## ❖ CHECK YOUR INSTALLATION:

- Provide a Start Input to the Controller to start a sensing cycle.
- If the Swing Arm Assembly was installed properly and an adequate swing angle was selected, the Needle will contact the “Item”, and the Swing Arm will return to its Start Position/Home Position (*the Green OK LED on the Control will illuminate*).
- Next, simulate a broken/missing “Item” by removing such “Item” and provide another Start Input. The Needle will travel beyond the target position and immediately return to its Start Position/Home Position once it reaches the mechanical stop (*the Red FAULT LED on the Controller will illuminate*).
- Replace the “item” and provide a Start input, the Needle will again contact the “Item”, and the Swing Arm will return to its Start Position/Home Position (*the Green OK LED on the Control will illuminate*)

For questions regarding the PCS product line or for additional installation assistance, please visit Allora International at [www.alloraintl.com](http://www.alloraintl.com), email us at [info@alloraintl.com](mailto:info@alloraintl.com), call us at 855.TOOL.911 (855-866.5911), or contact your local distributor.



## PCS-100 System Troubleshooting Guide

Please refer to the section that best describes the problem you are having.  
Determine if you can answer YES, to all of the questions.  
If not, attempt to correct the condition.  
If you have any questions, please contact our Technical Support department  
at 1.855.TOOL.911 (855.866.5911), or [info@alloraintl.com](mailto:info@alloraintl.com).

### **System Fault:** (SYS FAULT LED flashing)

- Is the PCS Sensor properly connected to the Controller?
- Are the Sensor Cable wires properly associated on the connector plug as per to the color code chart?
- Is the Needle returning to its start position (Home Position) at the end of each sensing cycle?

### **BSC-4000 Will Not Start:**

- Is the Start Input being applied to the correct Terminal/Pin?
  - TB2 Pin 2 Start (based on the established Controller Dip-Switch selection)
  - TB2 Pin 3 Start (same as TB2 Pin 2)
- Is the Start Input Common connection present?
  - The input can be 0VDC or +24VDC (either NPN or PNP)
  - If using the *low* condition 0 V the *low* condition **must be 0 V**.
    - If the *low* condition is not an absolute 0 V, the BSC-4000 may not recognize the input
  - if using the *high* condition 24V, is the TB2 Pin1 connected to 0V (same as TB3 Pin 2, 0V) ?
  - Is each change in condition being held for at least 100ms?
- Is the Controller placed in an environment with a lot of electrical noise, (i.e.: large motors or motor starters)?
- Is the Start Input being applied **after** the BSC-4000 has finished its last sensing cycle (as indicated by a Fault or Ok Output)?

### **Fault Signal When Tool is Ok:** (Given an Ok condition, BSC-4000 gives Fault Output)

- Is the PCS Sensor set to swing in the correct direction to contact the tool?
- Is the tool/object being monitored within the PCS Sensor operating swing angle?
  - The PCS Sensor Swing Arm should be set to swing freely at least 10° past the tool for the best results
  - The Needle's tip should extend over the tool's centerline (make a positive contact with tool/object)
  - In case of a tool monitoring, the Needle should contact the tool at least 1.6mm from the tool's tip
- Are the PCS Sensor Top Cap set screws holding the Needle properly tightened?
- Is the Clamping Sleeve tight on the PCS Sensor, and tight on the mounting bracket?
- Is the Swing Arm Assembly tight on the PCS Sensor?
- Is the PCS Sensor connected properly?
  - Color coded wires of the Sensor Cable must be attached to the correct terminals on the BSC-4000
  - The inside of the PCS Sensor connector and the Sensor Cable connector should be dry
  - Sensor Cable should be screwed tight to the PCS Sensor
- Is the Needle or wand being used an Allora's supplied product?



**No Fault Signal When Tool is Broken:** (Given a Fault condition, BSC-4000 continues to give Ok Output)

- Is the Dip Switch setting set high enough for the Swing Arm to reach the tool/object being detected ?
- Is the Clamping Sleeve and Insert tight on the PCS Sensor, and tight on the mounting bracket?
- Is the Swing Arm Assembly tight on the PCS Sensor?
- Is the Swing Arm on the PCS Sensor swinging *at least 10°* from its home position?
- Is the PCS Sensor connected properly?
  - Color coded wires of the Sensor Cable must be attached to the correct terminals on the BSC-4000
  - The inside of the PCS Sensor connector and the Sensor Cable connector plug should be dry
  - Sensor Cable connector plug should be screwed tight to the PCS Sensor connector.

**No Power to BSC-4000:** (No LEDs illuminate on BSC4000 at power-on and no power to Sensor)

- Is a "clean" 24VDC being supplied to TB3 Pin 1 & 2 (Power "+" & "-") on the BSC-4000?
  - Is the polarity correct (TB3 Pin 1 = 24VDC, & TB3 Pin 2 = 0V)?
- Is the 24VDC Power Supply properly sized to operate with the BSC-4000?

**No Output from BSC-4000 :** (Machine doesn't receive Ok or Fault signal after applying Start Input)

- Is the SYS FAULT LED off?
  - If not, see **System Fault**
- Does the Swing Arm on the PCS Sensor swing when the BSC-4000 is given a Start Input?
  - If not, see **BSC-4000 Will Not Start**
- Is the OK LED or FAULT LED illuminated and at its normal intensity?
  - If not, see **No Power to BSC-4000**
- The Outputs from the BSC-4000 are momentary (~100ms); is this adequate time for your application?
  - The Outputs from the BSC-4000 can be set to latch (refer to Page 6 and 12)
- With tool/object present, give the BSC-4000 a Start Input. Do contacts on TB4 Pin 1 & 2 (Ok Output) close (or open if NC switch for Ok Output is selected)?
  - This same check can be done for the Fault Output by removing the tool/object. Do contacts on TB4 Pin 3 & 4 (Fault Output) close (or open if NC switch for Fault Output is selected)?

**No Power to Sensor:** (Sensor does not swing or return to the Start/Home Position)

- Are one or more LEDs on the BSC-4000 illuminated?
  - If not, see **No Power to BSC-4000**
- Is the PCS Sensor connected properly?
  - Color coded wires of the Sensor Cable must be attached to the correct terminals on the BSC-4000
  - The inside of the PCS Sensor connector and the Sensor Cable connector should be dry. Sensor Cable should be screwed tight to the PCS-100.
- Manually move the Needle away from the Start/Home Position. Does the Needle return to the start position on its own?
- Is there 24VDC across terminals 1 & 2 (Power "+" & "-") on the BSC-4000? Is the polarity correct?
  - If not, see **No Power to BSC-4000**



Positive Contact Controllers conform with the EEC directive EMC 89/336/EEC as amended by 92/31/EEC and 93/68/EEC.

In compliance with the directive, the EC Declaration of Conformity and related Technical Documentation is maintained at the following address. for inspection by the appropriate officials:

Allora International, LLC  
N60W22951 Silver Spring Dr., Unit 15  
Sussex, WI 53089  
United States of America

**THIS INFORMATION MAY BE UPDATED BASED ON EMC  
AUTHORITIES REVIEW OF THE CURRENT CERTIFICATION**

**Positive Contact – Hazardous Materials Declaration**

- All **Positive Contact** products and packaging are manufactured with RoHS compliant materials. They are free of Bromide Halogens (PBB, PBDE), Mercury, Cadmium, and Chrome 6+.
- All **Positive Contact** products are Lead Free.
- All **Positive Contact** products comply with current EU environmental standards, including directive amendments regarding the use of perfluoro octane sulfonates, (PFOS).
- All **Positive Contact** products and packaging are free of any material containing Asbestos.
- All **Positive Contact** foam packaging is free of CFC's, HCFC's or HFC's. The foam and its ash is non-toxic, landfill safe and recyclable.



RoHS Compliant

