

Allora BSC Series Controller  
For  
PCS-350 Sensors

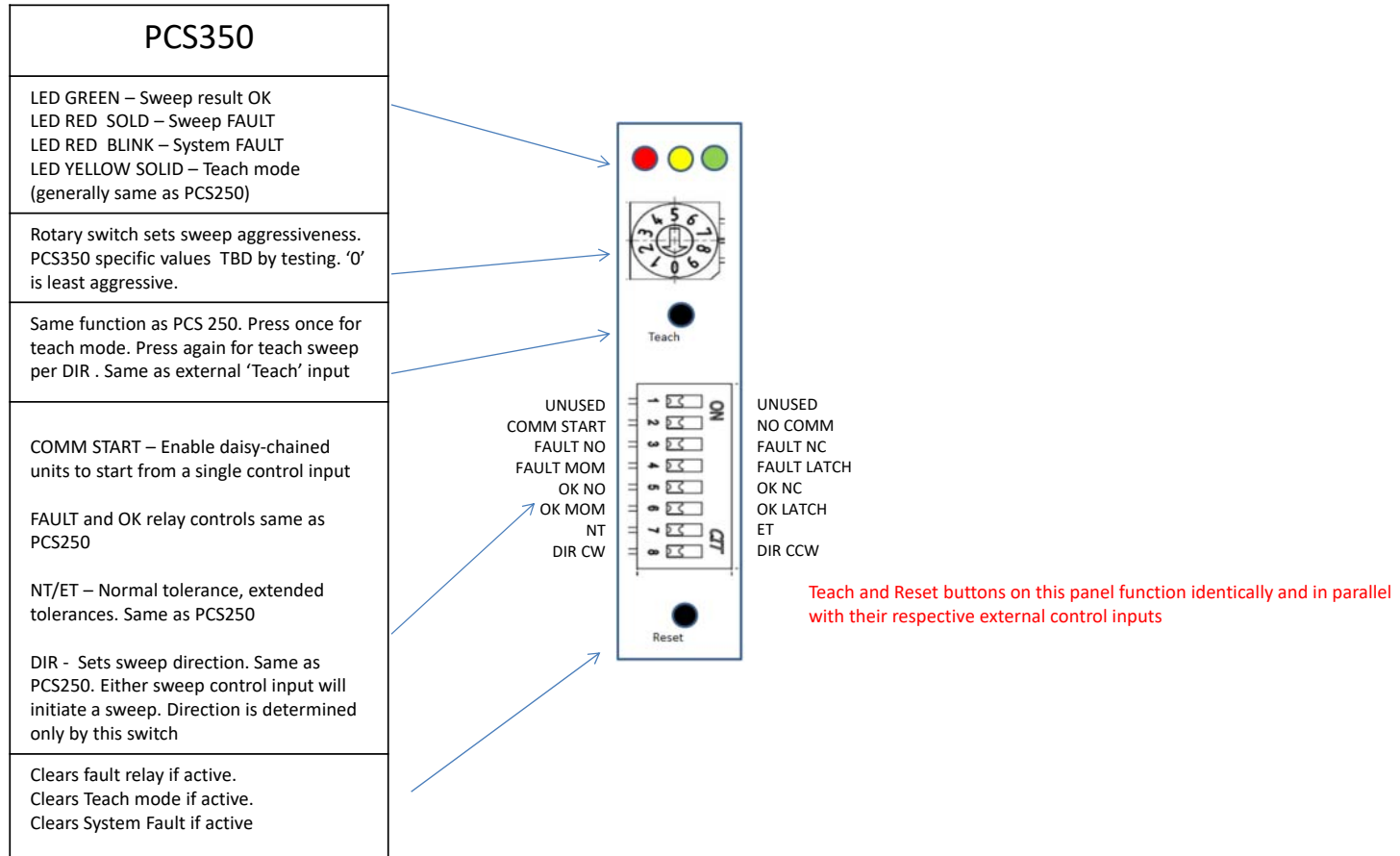

# Front Panel Controls for the PCS-350



# Daisy-Chained Option

A group of units could be daisy-chained together to reduce wiring.  
They can share power, CAN, start, reset, teach  
Each has it's own sensor.

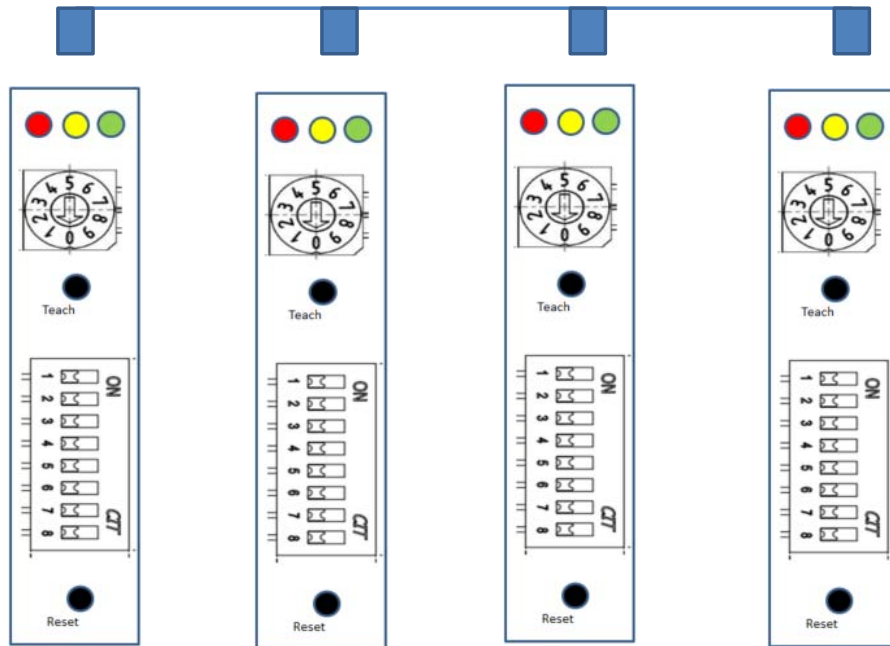

# Connection & Wiring Guide

J4 and J5 are IDC ribbon for daisy-chaining units. Each may be used independently. The daisy-chain ribbon cable may be cut with sharp scissors to remove unwanted connections or simply left floating.

J5 allows power and TB5 to be connected at one unit, then distributed to others

J4 distributes Starts, Teach, and Reset controls to additional units

When a daisy-chain ribbon is in place, Teach and Reset circuits are always distributed across the units. One wired unit will control the others. This can reduce system wiring complexity.

The Start circuit distribution is controlled from a front-panel dipswitch setting. This allows for units to simultaneously or independently started. If simultaneous starts are desired, one unit can be wired with the start signal; the others will be started through the daisy-chain connection. Otherwise, each unit would require it's own start signal

Designator	Mfr.	Mfr PN
TB1	Würth Elektronik	691361100005
TB2	Würth Elektronik	691361100008
TB3	Würth Elektronik	691361100003
TB4	Würth Elektronik	691361100004
TB5	Weidmüller	1597390000
P4 (assy)	Allora Intl.	TBD
P5 (assy)	Allora Intl.	TBD

To PCS350 or ER+ sensor  
Follow color convention listed for Allora provided cables

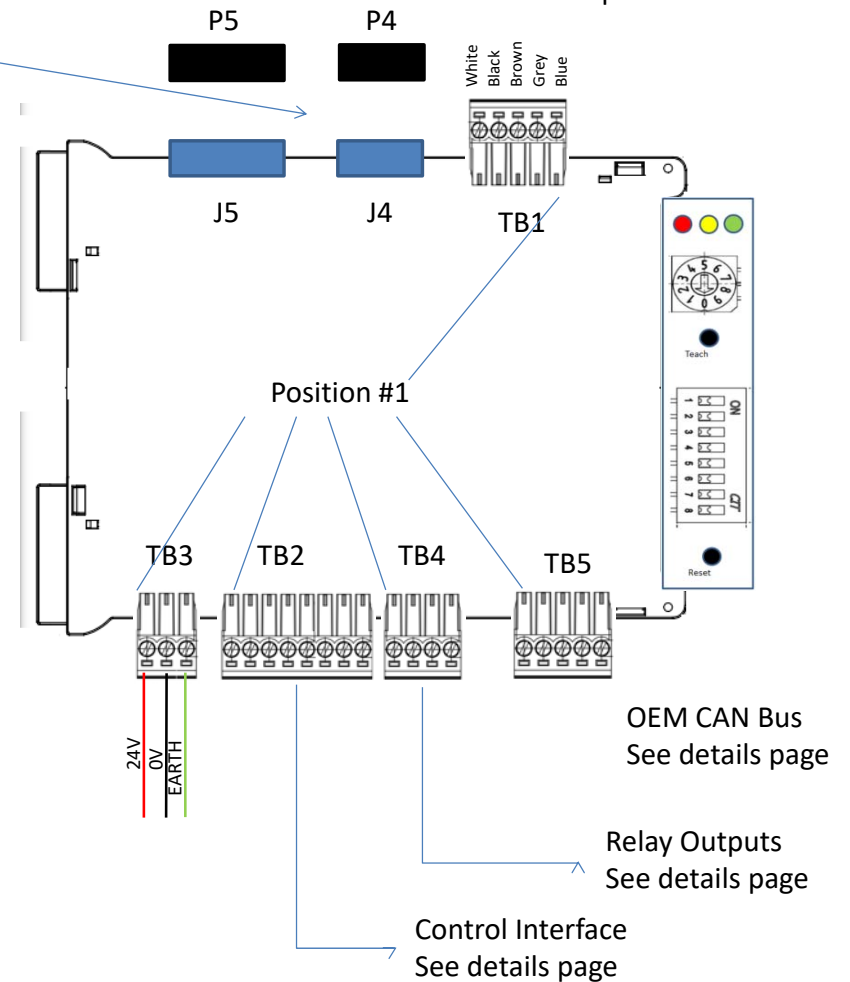

OEM CAN Bus  
See details page

Relay Outputs  
See details page

Control Interface  
See details page

# TB2 Control Interface Details

This interface provides four 24V control inputs, a power-limited 24V source, and two open-collector type outputs for status indication

Note that the common for the inputs is provided (Pin 1) and not connected internally. This allows for operation with NPN or PNP type controls.

The 4 inputs:

1. Start\_1 – When active, a sweep cycle is initiated\*
2. Start\_2 – When active, a sweep cycle is initiated\*
3. Fault\_Reset – Clears a faulted condition when activated
4. Teach Mode – First activation places the unit into teach mode. Second activation will initiate the position learning sweep

\***PCS350 Sensor** - the Start\_1 and Start\_2 inputs are redundant. Activation on either one will initiate the sweep as determined by the front panel switch setting. Only one is required.

The 24V source and 2 open collector provide a mechanism for remote status indication. These can drive LEDs to indicate 'Teach Mode' and 'Fault' conditions.

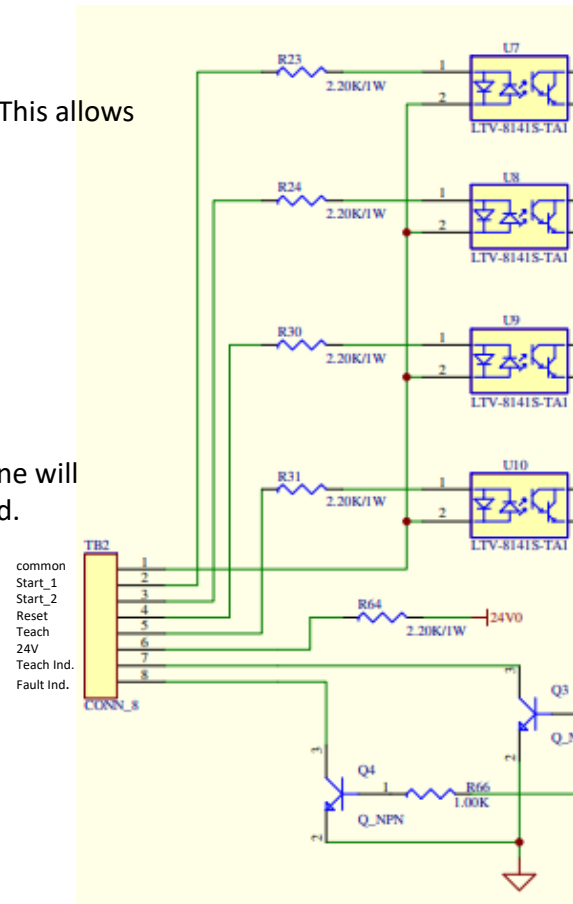
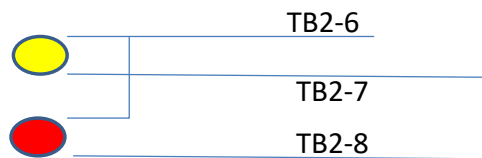

# Relays

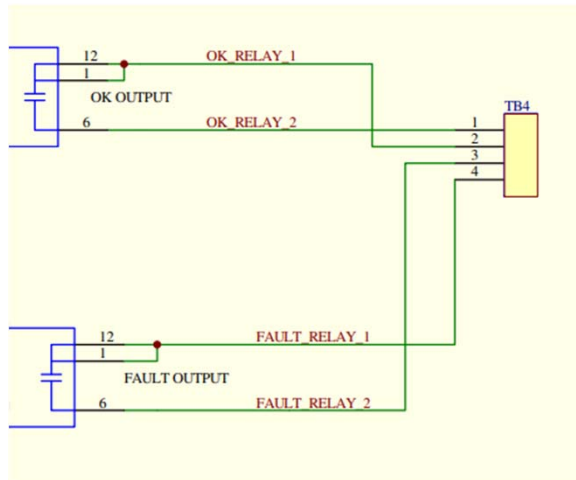

Two relays are provided to signal for OK or FAULT responses to teach and detect sweeps

When operating in the non-latching mode, toggle time is 450ms

Relays are 'dry' contact types

Contacts are rated at 5A@125VAC

## 7.3 Open style connector

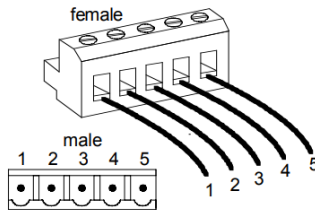

TB1 and TB5

Wiring follows the CANOpen wiring convention

If Open Style Connectors are used the following pinning is recommended:

Pin	Signal	Description
1	CAN_GND	Ground / 0 V / V-
2	CAN_L	CAN_L bus line (dominant low)
3	(CAN_SHLD)	Optional CAN Shield
4	CAN_H	CAN_H bus line (dominant high)
5	(CAN_V+)	Optional CAN external positive supply (dedicated for supply of transceiver and opto-couplers, if galvanic isolation of the bus node applies)

# Notes

## **Power-up**

- At Power-up the system is designed to perform a self-test and an internal boot cycle. This process takes about 10 seconds.
- After the initial cycle is completed, the sensor is powered and moves to its mechanical stop in a CW or CCW direction based on the preselected dipswitch setting.
- If the rotation direction dipswitch setting is changed, the sensor needs to learn a new tool position to maintain detection accuracy

## **System Fault**

- A system fault condition (indicated by a blinking red fault light) results from some hardware failure
  - The wand cannot return to its home position after a detect or teach cycle
  - The wand cannot return to its home position on a power-up
  - The controller is unable to communicate with the sensor
- PCS-350 with Allora controller, system response
  - After correcting the condition causing the fault, the recovery procedure is to press either the front panel 'Reset' button or activate the External reset line.
  - The controller will cycle power to the sensor, then self-reset and command the sensor to home position.
  - The green OK led will activate on success.
  - The system is now ready for normal operation.
  - The Wand will return normally to home position

## **Demo Mode**

- All Controllers are equipped with an AUTO-RUN feature mainly used for DEMO mode and other internal Proprietary diagnostic tests.
- To activate this mode, press and hold the Teach push button while powering up the Controller and continue to hold for about 10 seconds
- Upon releasing the button, the Controller will go into a self-diagnostic mode (about 10 seconds) and begin to cycle the sensor rotating in the direction previously selected.
- To terminate this mode power-off the Controller and power-up again without pressing any buttons..

# Compliance & Standards



**RoHS Compliant**

## **Positive Contact – Hazardous Materials**

All **Positive Contact** products and packaging are manufactured with RoHS compliant materials. They are free of Bromide Halogens (PBB, PBDE), Mercury, Cadmium, and Chrome 6+.

All **Positive Contact** products are Lead Free.

All **Positive Contact** products comply with current EU environmental standards, including directive amendments regarding the use of perfluorooctane sulfonates, (PFOS).

All **Positive Contact** products and packaging are free of any material containing Asbestos.

All **Positive Contact** foam packaging is free of CFC's, HCFC's or HFC's. The foam and its ash is non-toxic, landfill safe and recyclable.



**Allora International, LLC • N60W22951 Silver Spring Dr. Unit 15 • Sussex, WI 53089**

---

**Phone +1.262.246.6800 • Fax +1.262.246.6866 • Website [www.alloraintl.com](http://www.alloraintl.com) • E-Mail [info@alloraintl.com](mailto:info@alloraintl.com)**